

850 MAX COMPUSPOT

AMH®

ADVANCED INVERTER SPOT WELDERS WITH TWO CLAMPS

An advanced Inverter spot welder equipped with two liquid cooled clamps for a maximum coverage of the car body. The ideal answer for how to weld today's high strength dual phase and boron steels.

C Clamping force of over 1,420lbf at 125psi
(630daN at 8,5bar).

G Clamping force of over 1,240lbf at 125psi
(550daN at 8,5bar).

USB port for data transfer and program updates.

Weld history log recording
each weld performance.

Assisted mode with factory presets of 5 metal
types and 8 metal thickness.

The reports saved on the USB key.

Liquid cooling all the way
to the electrode tips.

7" touch screen control panel with
high resolution color
(800x480 pixels).

Fully compliant with
European directive 2004/40/CE.

550 daN G Clamp included



No. Model (440-480V): 28.CPS.855M
No. Model (380-415V): 28.CPS.854M
No. Model (208-230V): 28.CPS.853M

Turning Innovation Into Productivity

COMPUSPOT 850 MAX

More power in action with two clamps...

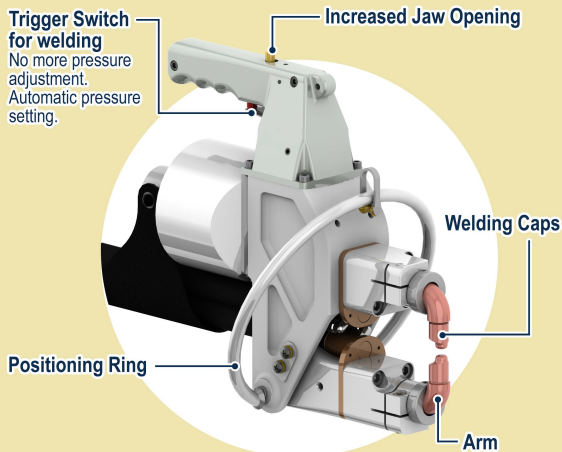

Maximum Maneuverability:
Clamp and cable support;
Wide range of positions;
Easy access to the workpiece.

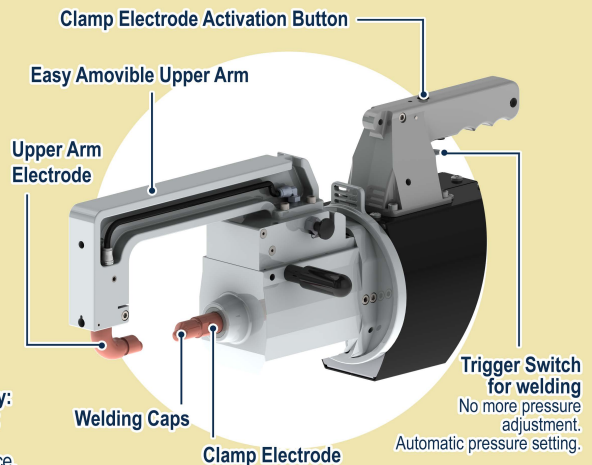

C CLAMP 630daN

G CLAMP 550daN

Control panel display



Touch screen for easy operation:

- Pre-programmed tool selections;
- Memory slots;
- 7" high definition LCD display.

Accessories for C Clamp

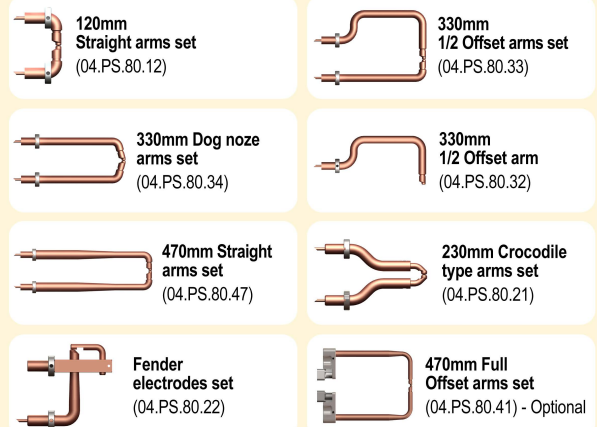

Accessories for G Clamp

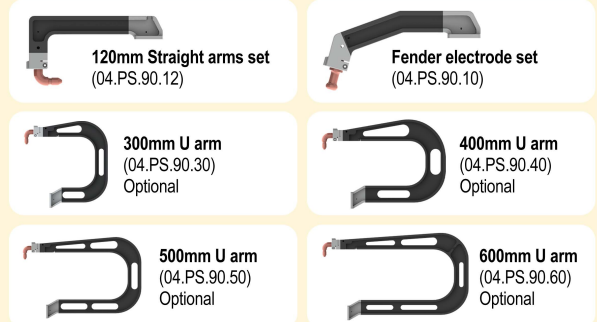

Technical information

Nominal input power.....	208-230V / 380-415V / 440-480V 3-Phase
Fuse or breaker.....	80A (208-230V) / 32A (380-415V) / 40A (440-480V) Slow blow
Secondary short-circuit maximum current (RMS).....	14,000A
Frequency.....	50Hz / 60Hz
Welding frequency.....	2,000Hz
Welding cable length.....	2.5m (8')
Cooling system (cable, arms and cap).....	Liquid
Nominal operating temperature.....	30°C (86°F)
C-Clamp Tip pressure @ 8,5bar (125psi).....	630daN (1,420lbf)
G-Clamp Tip pressure @ 8,5bar (125psi).....	550daN (1,240lbf)
Weight.....	195kg (430lbs)

Complete single side welding and dent pulling package included.



AMH Canada Ltd, 391 rue Saint-Jean-Baptiste Est, Rimouski (Québec) Canada G5L 1Z2

CANADA and other countries Tel: (418) 724-4105 Fax: (418) 722-6108 EUROPE Tel: ++33 616 995 408 USA Tel: (910) 371-9313 Fax: (910) 371-9417

